

TLS2200™ Quick Start Guide

Step 1. Charge the Battery

Charge the battery pack for a minimum of 5 hours before initial use.

Step 2. Install the Battery

1. Turn the battery power switch to the *off* (O) position.
2. Slide the battery release lever to the unlock position. (slide to left)
3. Drop the battery in as shown and slide forward.
4. Slide the battery release lever to the lock position. (slide to right)

Step 3. Turn the Power On

Turn battery power switch to the *on* (I) position.

Step 4. Select Your Marker & Ribbon

Refer to the chart in the User's Guide to select the correct marker and ribbon for your task.

Step 5. Install Ribbon Cartridge

1. Remove cartridge from the bag. Avoid touching or creasing the ribbon.
2. Remove any ribbon slack by rotating take-up spool end counter-clockwise.
3. Slide ribbon cartridge firmly into printer. (Locking lever must be in unlock position – see below.)
4. Push the locking lever towards the back of the printer to close the print head and lock the ribbon cartridge in place.

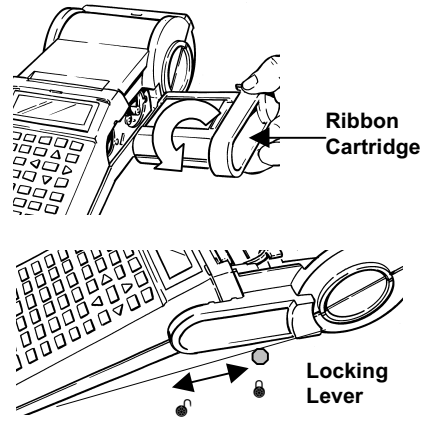
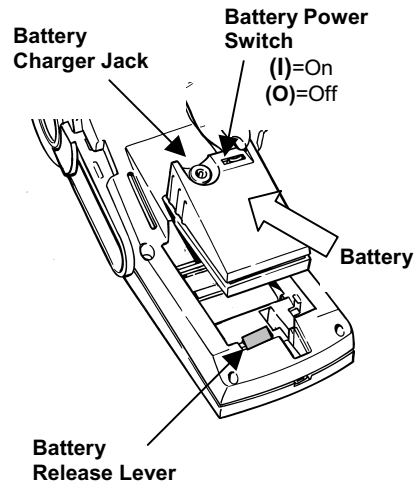

OVER →

Step 6. Remove/Install Marker Roll

To remove a marker roll:

1. Cut off printed labels with the cutter lever.
2. Open the roll door.
3. Slide the locking lever to the unlock position.
4. Back the markers out of the material guide slots.
5. Pull the marker roll out of its cradle.

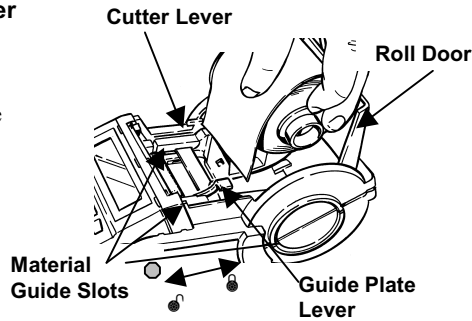

To install a marker roll:

1. Slide the locking lever to the lock position.
2. Turn the power switch on.
3. Open the roll door.
4. Pressing the guide plate lever down, slide and snap it into a notch that matches your marker roll width.
5. Making sure labels unwind from the top, snap the marker roll firmly into cradle.
6. Press **<Enter>** to clear the "ERROR No Label Present" message.
7. Feed leading edge of marker roll through the guide slots.
8. Press **<Feed>**. (Continue to manually push marker roll edge until it catches.)
9. Close the roll door.

Step 7. Create & Print a Label

The status bar will be on the first line of the display. Refer to the User's Guide for further information on each heading.

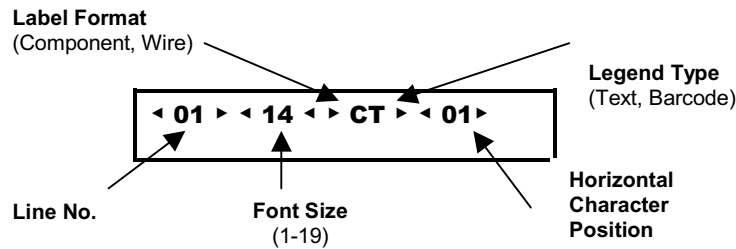

1. Type text. Refer to the User's Guide for guidelines on typing and editing text.
2. Press **<Print>** on the keypad to print your label.
3. To turn off the printer, turn the battery power switch to the *off* (O) position.



IDENTIFICATION SOLUTIONS & SPECIALTY TAPES
P.O. Box 2131 • Milwaukee, Wisconsin 53201-2131 U.S.A.
Phone 1-800-537-8791 • www.bradyid.com or www.tls2200.com